

# Emotron DCM Control Unit



Data sheet  
English

The Emotron DCM is a control unit that remotely controls submersible pump equipment. Level sensors are not needed to initiate start and stop. The pump stops automatically when it begins to snore (draw air), when the pit has been pumped free from water. During a pumping operation, the Emotron DCM measures the length of the run period and uses this to determine the length of the rest period. The longer the run period, the shorter the rest period. As a result the run and the rest periods are continuously adapted to the rate of flow.

Two Emotron DCM can be connected in parallel to control two submersible pumps and allow independent operation and display of monitored values. The “dual-pump DCM system” must not be installed in a pit of extremely small diameter or width. This will result from time to time in the DCMs failing to detect the stop/minimum level.

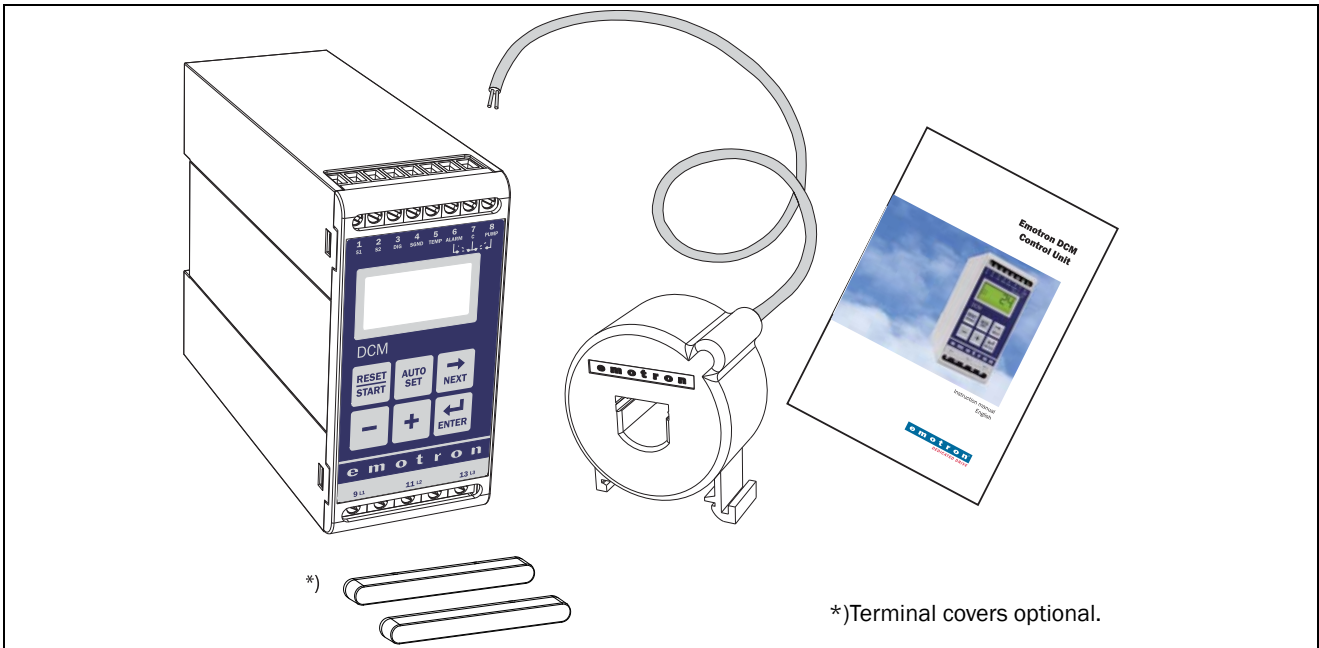

Fig. 1 Emotron DCM and current transformer (CT), both for mounting on standard DIN rail 35mm.

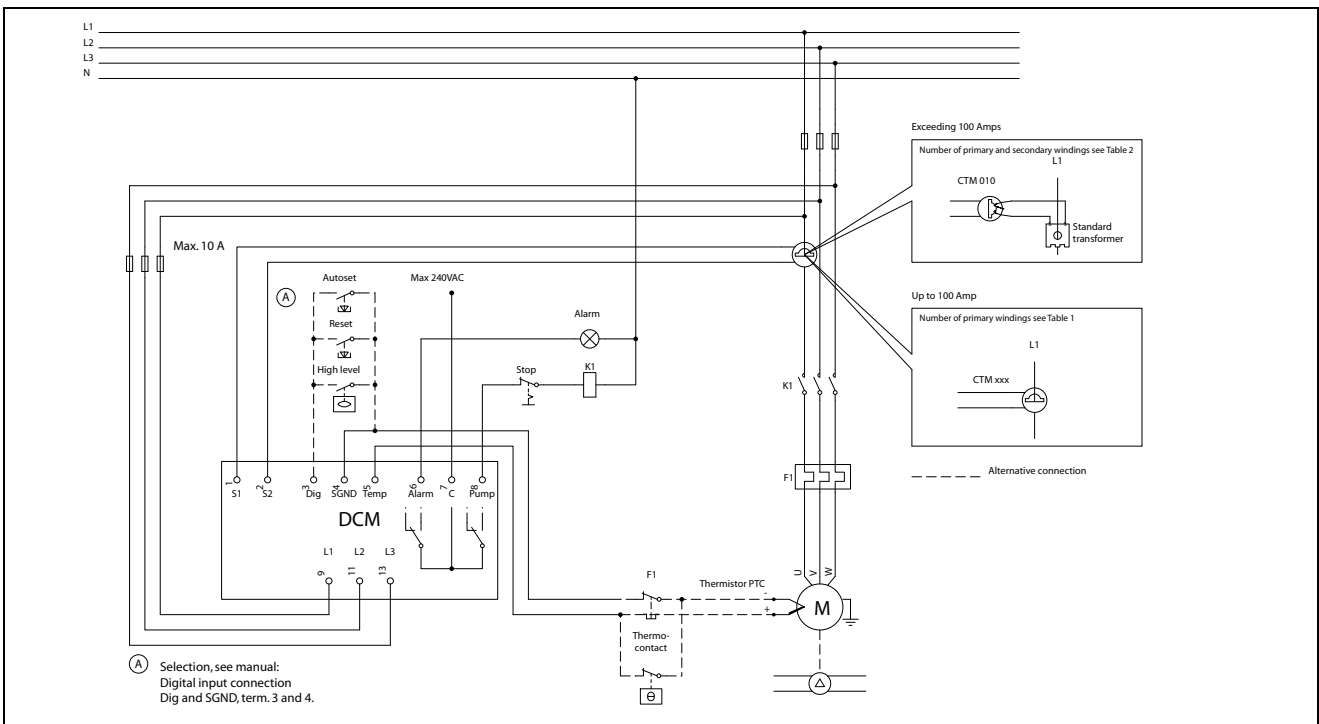

Fig. 2 Connection example

**NOTE: Make sure that the DCM voltage range e.g. 3x380-500 VAC matches the connected pump motor/line voltage, e.g. 3x 400 V.**

Table 1 Motor and Current transformer less than 100 A

| Rated motor current | Choice of current transformer and number of windings for different pump motor sizes. |        |        |         |
|---------------------|--|--------|--------|---------|
|                     | CTM010   | CTM025 | CTM050 | CTM0100 |
| 0.4 to 1.0 A        | 10   |        |        |         |
| 1.01 to 2.00 A      | 5  |        |        |         |
| 2.01 to 3.0 A       | 3  |        |        |         |
| 3.1 to 5.0 A        | 2  |        |        |         |
| 5.1 to 10 A         | 1  |        |        |         |
| 10.1 to 12.5 A      |  | 2      | 4      |         |
| 12.6 to 25 A        |  | 1      | 2      |         |
| 26 to 50 A          |  |        | 1      |         |
| 51 to 100 A         |  |        |        | 1       |

In order to ensure an accurate calibration of the DCM, it is essential that you use the correct CTM and apply the exact number of windings in accordance with the tables.

Table 2 Current transformer greater than 100 A

| Rated motor current | Current transformers Number of windings |        |             |
|---------------------|---|--------|-------------|
| 101 to 150 A        | 150:5<br>1                              | +<br>+ | CTM010<br>2 |
| 151 to 250 A        | 250:5<br>1                              | +<br>+ | CTM010<br>2 |
| 251 to 500 A        | 500:5<br>1                              | +<br>+ | CTM010<br>2 |
| 501 to 999 A        | 1000:5<br>1                             | +<br>+ | CTM010<br>2 |

---

**NOTE: The current transformer (CTMxxx) must be placed in the same phase that is connected to terminal 9, phase L1, see Fig. 2, page 1.**

---

## Technical Data

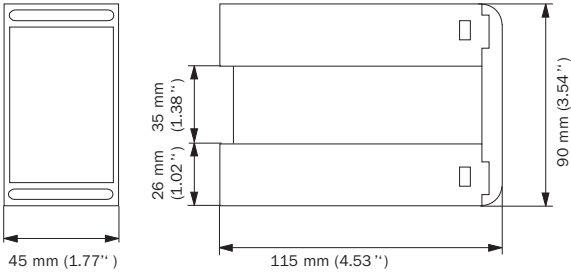
|  |   |
|--|---|
| <b>Dimension (WxHxD)</b>               | <p>45 x 90 x 115 mm (1.77" x 3.54" x 4.53")</p>                                       |
| <b>Mounting</b>                        | 35 mm DIN rail 46277  |
| <b>Weight</b>                          | 0.3 kg (10.5 oz)  |
| <b>Supply voltage (VAC)</b>            | <p>3 x 100 to 240,<br/>3 x 380 to 500,<br/>3 x 525 to 690 (±10%)</p> <p><b>NOTE: that these are separate voltage units; see table with order numbers on page 4.</b></p> |
| <b>Frequency</b>                       | 45 to 65 Hz   |
| <b>Current input</b>                   | Current transformer CTM010, 025, 050 or 100. (If rated current >100 A, CTM010 and a standard transformer)   |
| <b>Power consumption</b>               | 6 VA max.   |
| <b>Start-up delay</b>                  | 1 to 170 s  |
| <b>Stop delay</b>                      | 1 to 90 s   |
| <b>Digital input terminal 3</b>        | For closing contact. Internal supply 15 - 30 VDC, short-circuit current 10 - 20 mA  |
| <b>Temperature input terminal 5</b>    | Internal supply 15-30 VDC, short-circuit current 2 mA - 2.5 mA  |
| <b>Relay output</b>                    | 5 A 240 VAC Resistive. 1.5 A 240 VAC Pilot duty/AC12  |
| <b>Fuse</b>                            | 10 A max.   |
| <b>Terminal wire size</b>              | Use 75°C copper (CU) wire only. 0.2 to 4.0 mm <sup>2</sup> single core (AWG12), 0.2 to 2.5 mm <sup>2</sup> flexible core (AWG14), stripped length 8 mm (0.32").         |
| <b>Terminal tightening torque</b>      | 0.56 - 0.79Nm (5-7 lb-in)   |
| <b>Repeatability power measurement</b> | ±1 unit 24 h; +20°C (+68°F)   |
| <b>Temperature tolerance</b>           | < 0.1% / °C   |
| <b>Operating temperature range</b>     | -20°C to +50°C (-4°F to +122°F)   |
| <b>Storage temperature range</b>       | -30°C to +80°C (-22°F to +176°F)  |
| <b>Protection class</b>                | IP20  |
| <b>RoHS directive</b>                  | 2002/95/EC  |
| <b>Approved to</b>                     | CE (up to 690 VAC), UL and cUL (up to 600 VAC)  |

## Ordering numbers

| Ordering number | Designation               |
|-----------------|---------------------------|
| 01-2110-20      | Emotron DCM 3x100-240 VAC |
| 01-2110-40      | Emotron DCM 3x380-500 VAC |
| 01-2110-50      | Emotron DCM 3x525-690 VAC |

## Technical Data for Current Transformer

| Type    | Dimensions (WxØ) | Weight* | Mounting             |
|---------|------------------|---------|----------------------|
| CTM 010 | 27 (35) x Ø48 mm | 0.20 kg | 35 mm DIN rail 46277 |
| CTM 025 | 27 (35) x Ø48 mm | 0.20 kg | 35 mm DIN rail 46277 |
| CTM 050 | 27 (35) x Ø48 mm | 0.20 kg | 35 mm DIN rail 46277 |
| CTM 100 | 45 (58) x Ø78 mm | 0.50 kg | 35 mm DIN rail 46277 |

\*)Weight including 1 m (39 inch) cable. Please note that the maximum length of the CTM cable is 1 m and this cable must not be extended.

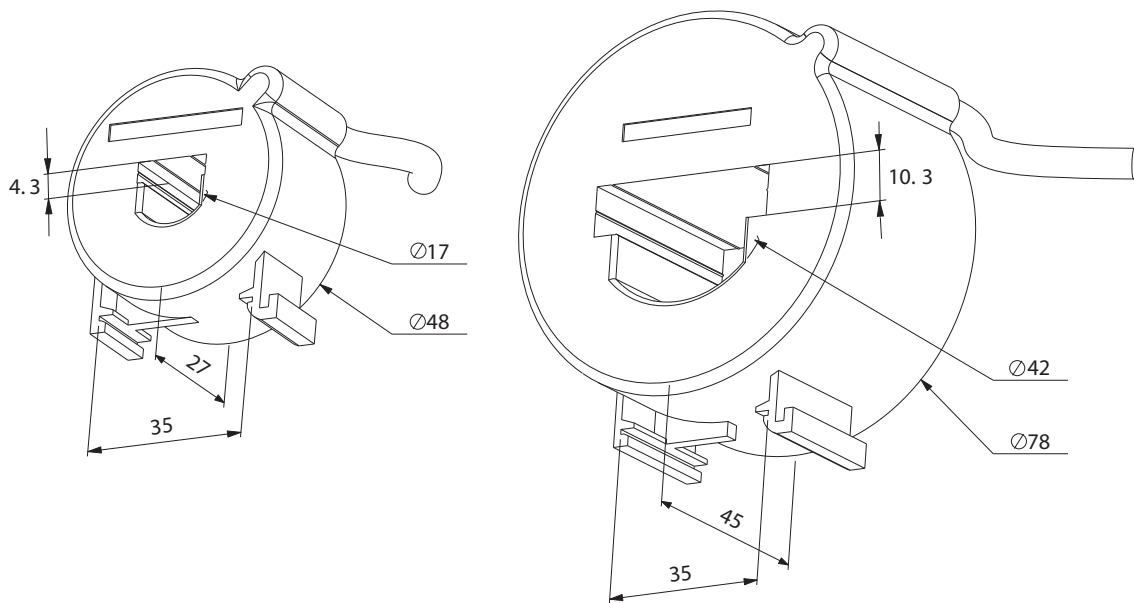

Fig. 3 Current transformer, CTM xxx.

## Accessories and documentation

| Ordering number | Designation                                     |
|-----------------|---|
| 01-2471-10      | Current Transformer (CT) CTM010, max. 10 A      |
| 01-2471-20      | Current Transformer (CT) CTM025, max. 25 A      |
| 01-2471-30      | Current Transformer (CT) CTM050, max. 50 A      |
| 01-2471-40      | Current Transformer (CT) CTM100, max. 100 A     |
| 01-2368-00      | Front Panel Kit 1 (2x terminal covers included) |
| 01-4136-01      | 2x Terminal covers                              |
| 01-2120-00      | Instruction manual (Swedish)                    |
| 01-2120-01      | Instruction manual (English)                    |

## EU (European Union) specifications

|                                 |              |
|---------------------------------|--------------|
| EMC                             | EN 61000-6-3 |
|                                 | EN 61000-6-2 |
|                                 | EN 61000-4-5 |
| Electrical safety               | EN 60947-5-1 |
| Rated insulated voltage         | 690 V        |
| Rated impulse withstand voltage | 4000 V       |
| Pollution degree                | 2            |

Terminals 3, 4 and 5 are basic insulated from the line and relay terminals.

# 1 Window Parameters

Table 3 Window parameters and defaults









| Window | Function  | Value                                      | Default | Custom setting |       |
|--------|---|--|---------|----------------|-------|
|        |   |  |         | Master         | Slave |
| 00     | Alarm indication. Flashes when alarm present (window becomes active only on alarm).<br>Symbol  flashing.   |  |         |                |       |
| 01     | Remaining time to next pump start. Standard window during pause. When the DCM is SLAVE --- appears.<br>Symbol  flashing and m (min) or s (second).                                     | 720 - 15 min.<br>900 to 0 s                |         |                |       |
| 02     | Pumping Time (PT) since the last pump start. Displayed when pumping. When the DCM is MASTER and the DCM SLAVE is pumping --- appears.<br>Symbol  flashing and m (min) or s (seconds).  | 0 to 90 s.<br>15 - 720 min.<br>12 to 999 h |         |                |       |
| 03     | Pumping Time (PT) after last pump start when the pump is started on high-level switch. Displayed when pumping after high-level switch.<br>Symbol  flashing and m (min) or s (seconds). | 0 to 900 s<br>15 - 720 min.<br>12 to 999 h |         |                |       |
| 04     | Measured power as percentage of the DCM's measurement range.<br>Symbol %.   | 0 to 125%                                  |         |                |       |
| 05     | Measured line voltage.<br>Symbol V.   | 0 to 999 V                                 |         |                |       |
| 06     | Measured peak power as percentage of the DCM measurement range. Press - and + (in this window) simultaneously for 3 seconds to reset the value.<br>Symbol %.  | 0 to 125%                                  | 0%      |                |       |
| 07     | Total pumping time in hours. Press - and + (in this window) simultaneously for 3 seconds to set the value to 0.<br>Symbol  .   | 0-99999                                    | 0       |                |       |
| 08     | Total number of pump starts. Press - and + (in this window) simultaneously for 3 seconds to set the value to 0.   | 0-99999                                    | 0       |                |       |
| 09     | Parameter lock.<br>Symbol  is displayed when parameter is locked.  | 0 to 999                                   |         |                |       |
| 11     | Stop level. Symbol %.   | 0 to 125%                                  | 0%      |                |       |
| 12     | Snore margin. Symbol %.   | 0 to 125%                                  | 4%      |                |       |
| 13     | Type of Auto set. Auto set when the pump is snoring (⌊)<br>(No liquid in the pit).<br>Auto set when the pump is not snoring (⌋)<br>(Liquid in the pit).   | (⌋) or (⌊)                                 | (⌋)     |                |       |
| 21     | Pit volume and level setting, see Fig. 11, page 23 and Fig. 14, page 32. See also note on page 22. NOTE! The window is not shown when the DCM is SLAVE.   | 1.0 to 10.0                                | 1.0     |                |       |
| 22     | Maximum pause time.<br>NOTE! The window is not shown when the DCM is SLAVE.<br>Symbol  .   | 0 to 900 s<br>15 - 720 min.                | 600 s   |                |       |
| 23     | Start-up delay.<br>Symbol  .   | 1 to 170 s                                 | 5 s     |                |       |

Table 3 Window parameters and defaults

| Window | Function   | Value         | Default | Custom setting |       |
|--------|--|---------------|---------|----------------|-------|
|        |  |               |         | Master         | Slave |
| 24     | Stop delay.<br>Symbol ⌚.   | 1 to 90 s     | 2 s     |                |       |
| 31     | High temperature on pump motor or motor protection alarm, terminal 5 (on). Turn off (OFF).   | on / OFF      | OFF     |                |       |
| 32     | Latched alarm, terminal 5 (on). Alarm not latched (OFF). Can only be used when window 31 is (on).  | on / OFF      | OFF     |                |       |
| 41     | Phase asymmetry permitted.   | OFF/ 5 to 50% | 10%     |                |       |
| 42     | Phase asymmetry latched alarm (on). Phase asymmetry alarm not latched. (OFF) Can be used when window 41 is set between 5-50%.  | on / OFF      | OFF     |                |       |
| 51     | Alarm relay (terminal 6 ALARM).<br><b>NC:</b> normally closed,<br><b>NO:</b> normally open.<br>The window isn't shown when DCM is MASTER   | NC/NO         | NO      |                |       |
| 52     | Operating relay to control the pump motors contactor (terminal 8 PUMP).<br>NC: Relay contact is closed when pump is pumping.<br>NO: Relay contact is open when pump is pumping.            | NC/NO         | NC      |                |       |
| 53     | Digital input for closing contact:<br>1 High-level switch<br>2 External reset<br>3 External Auto set (not used in dual-pump system).   |               | 1       |                |       |
| 61     | Measured current on the terminals S1 and S2.   | 0-70 mA       |         |                |       |
| 71     | Desired DCM function:<br>1 Single-pump system<br>2 Dual-pump system MASTER<br>3 Dual-pump system SLAVE.  | 1, 2, 3       | 1       |                |       |
| 72     | Pump alternating:<br>(on) Alternate by each pump cycle (OFF) The SLAVE DCM only starts when the DCM MASTER indicates a fault code.<br>NOTE! The window is not shown when the DCM is SLAVE. | on/OFF        | OFF     |                |       |
| 73     | Pump starts on high-level switch. (on) Both pumps start. (OFF) one pump starts.<br>NOTE! Window is not shown when the DCM is SLAVE.  | on/OFF        | OFF     |                |       |
| 99     | Default settings (dEF). User adjustments mode (USr).   | dEF/USr       | dEF     |                |       |





***DEDICATED DRIVE***

**Emotron AB, Mörsaregatan 12, SE-250 24 Helsingborg, Sweden**

**Tel: +46 42 16 99 00, Fax: +46 42 16 99 49**

**E-mail: [info@emotron.se](mailto:info@emotron.se)**

**Internet: [www.emotron.com](http://www.emotron.com)**